

Heat your cells and media, not the stage.



New Features

- Mode indicator (dynamic or imaging)
- TTL interface and footswitch mode activation
- Cold start acceleration
- Temperature output port for recording
- Heat shock activation
- Heated Lid power supply
- Remote setpoint port
- Temperature output (for analog recording)

Bioptechs Delta T® Controlled Culture Dish System

Finally a culture dish system specifically designed for live-cell microscopy! Now you can have accurate temperature control and high-numeric aperture compatibility in a convenient disposable culture dish system that even works in confocal applications.

- Easily adapted to a variety of specimen types from monolayered adherent cells to brain slice and tissue preps
- Low mass to thermo-regulate as opposed to conventional stage heaters
- Plate, incubate and observe without the need to transfer your cells
- Fast thermal recovery after perfusion (within seconds)
- Compatible with inverted and upright microscope stands
- Coverglass bottom for optimum optical compatibility
- No need for warm air blowers or stage heaters
- Direct first-surface heating to your cells
- Can also be cooled below ambient
- Perfusion available
- No pre-heating

Bioptechs is now introducing the next generation Open Culture Dish Micro-Environmental Control System: the Delta T4. In addition to the improvements to the popular Delta TC3 control algorithm, Bioptechs has incorporated years of customer requests into the Delta T4.



Limitations of Traditional Technique

- Stage heaters are inefficient, slow, and inaccurate
- Plastic dishes are poor conductors of heat
- Temperature does not recover quickly during or after perfusion
- Plastic dishes are not suitable for high resolution or polarization microscopy
- Nonuniform temperature distribution
- Unnecessary dead volume
- Usable aperture of dish limited by the opening in heat transfer plate
- Surface evaporation significantly contributes to non-linearity of temperature distribution

Advantages of the Delta T® Dish System

- Place cells onto coverglass and observe
- Highly accurate temperature control
- Fast thermal recovery
- Superior optical image
- Stage adapters to fit most popular microscopes
- Designed for inverted microscopes but ideal for water immersion objectives on uprights
- Immediate alarm if cell temperature changes
- Rigid mount for X, Y stability
- Uniform temperature distribution
- Cells unaffected by surface evaporation
- Numerous specimen adapters available

The Biopetechs, Inc. Delta T Culture Dish System is designed to simulate host conditions on the stage of your microscope and provide an optimal optical environment for microscopy. This two-step system allows you to plate your cells and observe them without having to transfer them to another structure. The system components are, the Controller, Stage Adapter, and Dishes. Accessories for Tissue Slice, Brain Slice, and other specimens are available.

An intelligent feedback loop passes an electrical current through a thin film coating on the underside surface of the glass substrate on which the cells are grown. Heat is applied directly to the cells without the inefficiencies associated with peripheral heating by traditional culture dish warmers. Biopetechs exclusively offers opaque culture dishes which eliminates the unwanted ambient light background for fluorescence imaging.

The controller features a real-time temperature display and fast learning curve to compensate for cooling due to surface evaporation while responding to temperature changes due to perfusion. There is also an alarmed protection circuit to safeguard the cells and an internal reference for the user adjustable calibration. The standard controller has a temperature range of ambient to 50 degrees C. Extended ranges are available upon request.

Delta T dishes have 35mm O.D. and a 23mm central aperture. The peripheral region of the dish is tapered to reduce the dead-volume and the height of the dish is 6mm to allow better access for micro-injection and micromanipulation. The dishes are a hybrid of polystyrene plastic and Desag 263 glass. The outer structure of the dish is available in opaque black or clear and come with a clear 0.5mm or no.1.5 glass coverslip bottom bonded to it. The dishes are also available in a plain glass unheated version.

You will find the Delta T® a reliable and indispensable addition to your microscope.

Delta T Stage Adapters and Accessories

Controller and Dish Accessories

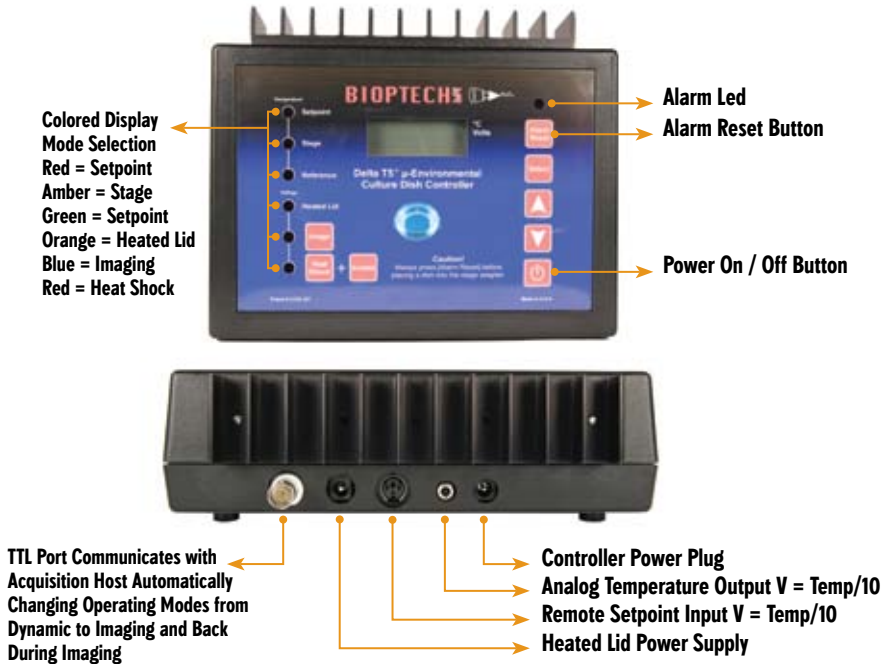

Hinged Perfusion Adapter

The Bioptechs Hinged Perfusion Adapter provides Delta T users with a convenient and inexpensive method of supporting perfusion needles in the culture dish. The typical application is to maintain low-volume perfusion over cells during long term-experiments. Perfusion adapters are sold in pairs. One hinge and needle is a supply, the other is a drain. The balance between supply and drain can be maintained continuously with the use of the Micro Perfusion Pump. Additional supports can be added to hold gas jets, pH probes, cooling apparatus, or other items which do not require critical positioning.

Hinged Perfusion Adapter



Coverglass Lid

The Coverglass Lid is a cover for the Delta T Culture Dish to be used when imaging to create an optical surface onto the liquid in the dish. This eliminates the optical effect of fluid motion at the air to liquid surface above the cells that causes the contrast of the image to change. Therefore, when acquiring a series of images in a transmitted light, contrast enhancing mode of microscopy, all images will have a uniform contrast.

Forming an optically flattened glass to media surface on the top of the cells eliminates this problem. The Coverglass Lid fits loosely on the Delta T Culture Dish and supports a 1 mm x 22 mm coverglass in the center of the field 3mm above the specimen. The Coverglass Lid is reusable and helps the Delta T bridge the gap between an open dish and a closed

Perfusable



Non-perfusable



Heated Lid**Heated Lid**

The Bioprotechs Delta T Heated Lid is a device which will provide a condensate free optical surface on the top of a Delta T Dish through which specimens can be perfused and trans-illuminated on an inverted microscope. It is reusable and powered by a 2.5 volt source from either a battery or the optional auxiliary power supply in the Delta T Controller. A CO₂ port is included.

The Bioprotechs Delta T Heated Lid w/ Perfusion is a device which will provide a condensate free optical surface on the top of a Delta T Dish through which specimens can be perfused and trans-illuminated on an inverted microscope. Specimens can be perfused by attaching perfusion tubing to the ports provided. It is recommended to use the Bioprotechs Micro-Perfusion Pump with the dual perfusion tubing for this purpose.

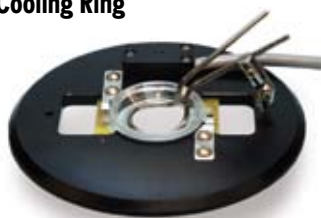
Cooling Ring**Delta T Cooling Ring**

The Bioprotechs Cooling Ring is an immersion device which absorbs heat from the specimen by providing a thermally conductive physical barrier between chilled fluid passing through the ring and the fluid surrounding the specimen. This cooling ring is made of autoclaveable 304 stainless steel and provides the microscopist with a convenient and inexpensive method of reducing the temperature of specimens in Delta T culture dishes. The cooling ring is supported on the stage adapter and translates along with the dish. It is easily flipped out of the way to enable easy exchange of dishes in the stage adapter.

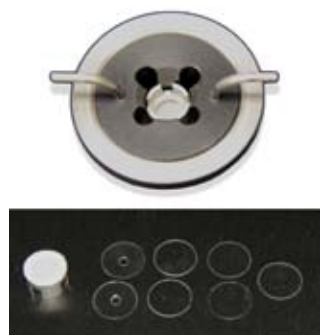
Brain Slice Adapter**Brain Slice Adapter**

The Bioprotechs Brain Slice Adapter is combined with the Delta T® Culture Dish System to provide a convenient method of observing thick cut sections of brain or other tissue in a perfusable, temperature controlled, optical environment on an inverted microscope. Perfusion ports are made of 304 stainless steel and are compatible with 1/16" tubing. As with all Bioprotechs Delta T® Culture Dish Adapters, the specimen is adjustable in the Z axis plane to accommodate the working distance of the objective. Custom geometry adapters are available upon special order to accommodate specimens having unique geometry.

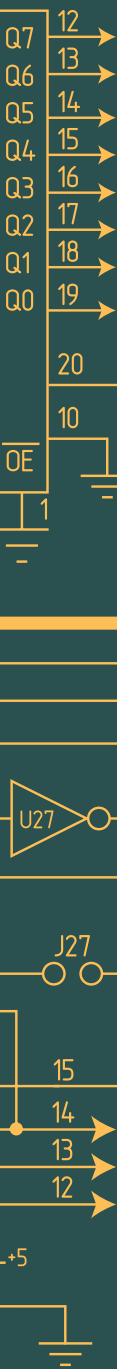

Biotechs Delta T Stage Adapters

The Biotechs Delta T Stage adapter reads the temperature of the Delta T Dishes, provides electrical contacts to power the dishes and supports the dish on the stage for translation. All Delta T systems require a Stage Adapter. These pictures are provided to assist in selecting a stage adapter appropriate for your microscope.

Stage Adapters



Delta T Ordering Information

Part No.	Product Description
Bi-0420-4-Start	Delta T Starter Kit - Heated Dish Stage Incl: Delta T Controller, 10pk of Delta T Dishes, Coverglass Lid, Heated Lid with CO ₂ port, Culture Cylinder Pack and Standard Stage Adapter
Bi-0420-4-03	Delta T4 Culture Dish Controller
Bi-04202003	Delta T Culture Dish Stage Adapters 96-Well Plate Sized
Bi-0420042105C	Delta T Culture Dishes (10/pk) 0.5mm thick glass (clear)
Bi-0420040500	Delta TPG Uncoated (no temperature control) Culture Dishes (10/pk) 0.5mm thick glass
Bi-0420201918	Delta T Tissue Slice Adapter
Bi-0420201919	Delta T Brain Slice Adapter
Bi-0420081601	Delta T Hinged Perfusion Adapter Set (2/set)
Bi-04200318	Delta T Cooling Ring
Bi-0420080316	Delta T Perfusable Heated Lid
Bi-070303-1919	Glass Culture Cylinder Starter Set (2, 4, 6, 8, 10 mm i.d x 5mm high)
Bi-070303-01	Glass Culture Cylinders -several sizes available
Bi-260700	Boekel Warmer
	Complete Biotechs product line available.

U.S./Canada prices shown. International prices add 15%. Email or visit web store for latest prices.



The system is comprised of

- Chamber
- Electronic Controller
- Stage Adapter

Accessories recommended for immersion objectives

- Objective Heater
- Objective Temperature Controller

Features

- Suitable for no flow through high rate flow procedures where a rapid exchange of media is required with low cell surface shear
- Cell temperature can be controlled from ambient to 50 degrees C +/- 0.2 degrees C without the need of an air curtain
- Temperature is controlled uniformly across entire field with media equilibrating as it enters the chamber
- Closed system so that bicarbonate CO₂ or organic buffers can be employed
- Compatible with 1/16" tubing for perfusion (C-Flex, Tygon, etc.)
- Easily assembled with ordinary skill (no tools required)
- Stand-alone temperature controller with an alarm circuit to safeguard your cells
- Near laminar flow
- Microaqueduct design enables proper Koehler illumination with high-numeric aperture optics for both transmitted and reflected modes of microscopy

Accurate temperature control with built-in laminar flow perfusion.

**FCS2 Closed Chamber for Inverted Microscopy**

After rigorous preparation your cells will need a micro-observation environment that is conducive to their viability, compatible with your experiments protocol and all techniques of microscopy!

The Focht Chamber System 2 (FCS2®) is a closed system, live-cell micro-observation chamber, that offers several advantages over other chambers. In addition to its unique perfusion and thermal control systems it is fully compatible with all modes of microscopy. It is also the only chamber to combine high-volume laminar flow perfusion rates with Koehler illumination and precise temperature control without an air curtain.

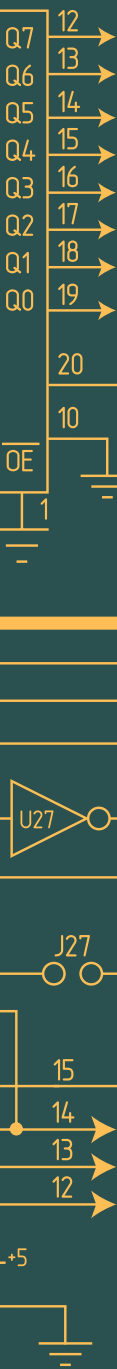

Temperature Control

The FCS2 was designed to maintain accurate thermal control and allow high-volume laminar flow perfusion. Both of these functions are incorporated into our patented Microaqueduct Slide. The surface of the slide, opposite the specimen side, is coated with an electrically conductive transparent thin film of Indium-Tin Oxide (ITO) and two electrical contacts (busbars). When the FCS2 is completely assembled two electrical contacts, which are contained in the electrical enclosure rest on the busbars. A temperature controller is used to pass a regulated current flow through the ITO Coating. This causes the surface of the slide to heat. The heat is transferred through the perfusable media to the cell surface on the coverslip thereby providing first surface thermal control. The self locking base of the chamber is also temperature regulated to provide peripheral heat as well.

Microaqueduct Perfusion

A fluid pathway is formed by separating the Microaqueduct slide from the coverslip containing cells with a single silicone gasket. This gasket can be any thickness from 50 micron to 1mm and any lateral geometry you choose or create. This arrangement allows the user to define the flow characteristics. Therefore, you are not limited by the geometry of the optical cavity instead you select or create it! Fluid access to this flow channel is made through two 14-gauge needle stock tubes protruding from the sides of the chamber top. These tubes provide fluid connection to two perfusion holes in the Microaqueduct slide that interface two "T" shaped grooves cut into the inner surface of the Microaqueduct slide. The "T" groove allows the media to seek the path of least resistance and become nearly laminar before flowing across the cells. This technique eliminates the need for the metal perfusion ring and additional gaskets, which are the limiting factors, required by most conventional chambers.

FCS2 Closed Chamber Ordering Information

Part No.	Product Description
Bi-060319-2	FCS2 Starter Set: FCS2 Chamber, Chamber Controller, 5 Microaqueduct Slides, 50-40mm, Coverslips, and Gasket Set (30/set)
Bi-060319-2-0318	FCS2 Stage Adapters Cell Robotics Adapter, others avail.
Bi-060319-2-03	FCS2 Chamber
Bi-060319-2-0303	FCS2 Chamber Controller
Bi-130119-5	Microaqueduct Slides (5/pk)
Bi-40-1313-0319	40mm Coverslips (250/pk) -other sizes available
	Complete Bioptechs product line available.

U.S./Canada prices shown. International prices add 15%. Email or visit web store for latest prices.

FCS2 Specifications

Physical Size:

75mm OD 13mm high

Coverslip No:

1.5 thick x 40mm Diameter

Imaging Aperture:

22mm

Maximum Volume:

706mm³

Minimum Volume:

<31mm³

Maximum Volume Exchange

Rate:

1/sec

Minimum Fluid Aperture:

0.6mm²

Separation between optical surfaces:

50 - 1000 microns

External port ID:

1.6mm

Temperature Stability:

+/- 0.2 degrees C

Important Notes

If you are using immersion objectives on mammalian specimens, you will need an Objective Heater!



The Gasket Set Includes:

- (3) 0.1mm 30mm Round
- (2) 0.1mm 14 x 24
- (3) 0.25mm 30 mm Round
- (2) 0.25mm 14 x 24
- (1) 0.25mm Blank
- (3) 0.5mm 30mm Round
- (2) 0.5mm 14 x 24
- (2) 0.5mm Blank
- (5) 0.75mm 30mm Round w/holes
- (2) 0.75mm 14 x 24
- (1) 0.75mm Blank
- (2) 1.0mm 30mm Round
- (1) 1.0mm 14 x 24
- (1) 1.0mm Blank

Custom shapes are available.
Simply contact AutoMate to make arrangements for their production.

Your stage,
your cells,
your flow.

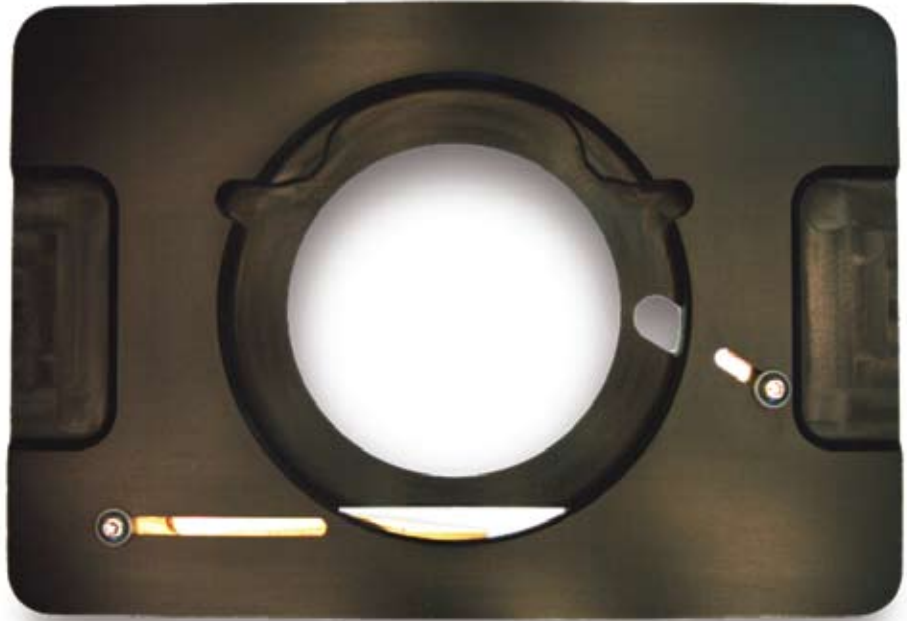

FCS2 Accessories and Stage Adapters

Singular Lower Gasket

By simply changing this one gasket you can change the volume of the chamber. This gasket can have any internal geometry you desire and can be any thickness from .1mm to 1mm. The drawing below shows the standard shapes of the gaskets that we include with every FCS2. We also include solid gaskets for you to custom fit to your application. Once you have found the shape that works best for your experiment you can contact us to have a die made to those specifications

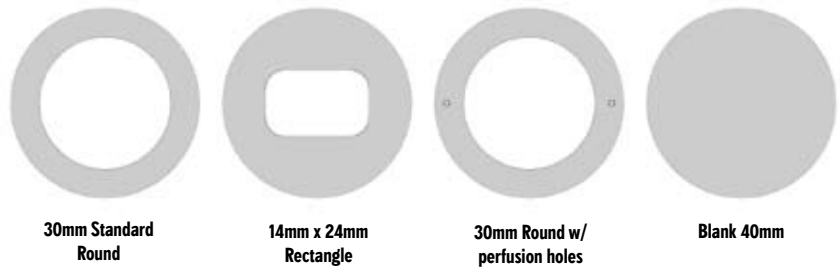

30mm Standard Round

14mm x 24mm Rectangle

30mm Round w/ perfusion holes

Blank 40mm





Open Mode Top for the FCS2

The open mode option allows for the FCS2 to be assembled without the microaqueduct slide thus exposing the cell on the cover slip for microinjection. The coverslip can then be removed and reassembled with the microaqueduct slide for long term, time-lapse.

Open Mode Adapter Installed on FCS2 Base



FCS2 Stage Adapters

The FCS2 Starter set requires a stage adapter for precise positioning. Due to the diversity of microscope stages, a stage adapter cannot be included with the FCS2 starter kit. Select a stage adapter for your scope from the drawings below. When ordering please indicate the brand of microscope and the manufacturer's stage identification number with the description and the corresponding Bioptechs part number. Custom designs are available upon special order.

Round Stage Adapter



FCS2 Cooling Adapter

This configuration is designed to allow high N.A. observation of specimens at below ambient temperatures on an inverted microscope. This design provides the same optical and flow characteristics as the warmed FCS2 but provides an adjacent secondary perfusion chamber through which a refrigerant fluid is circulated. Caution: When working below ambient temperatures with high numeric aperture lenses, an Objective Cooling Ring and Objective Thermal Isolator should be used.

Leica DMIRB

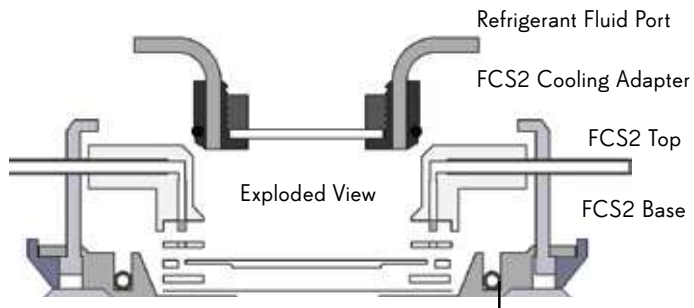

Zeiss IM35 with three plate stage



Zeiss IM35 with single plate



FCS2 Closed Chamber Ordering Information

Part No.	Product Description
Bi-060319-2-0719	FCS2 Gasket Set (30/set)
Bi-060319-2-0301	FCS2 Cooling Adapter
Bi-060319-2-1513	FCS2 Open Mode Adapter
Bi-060319-2-1242	FCS2 Low Dead Volume Top
Bi-03060319-2	Cooled FCS2 (CFCS2)
	Complete Bioptechs product line available.

U.S./Canada prices shown. International prices add 15%. Email or visit web store for latest prices.

Attributes

- Suitable for no flow through high rate flow procedures where a rapid exchange of media is required with low cell surface shear
- Cell temperature can be controlled from ambient to 50 degrees C +/- 0.2 degrees C without the need of an air curtain
- Temperature is controlled uniformly across entire field with media equilibrating as it enters the chamber
- Closed system so that bicarbonate CO2 or organic buffers can be employed
- Compatible with 1/16" tubing for perfusion (C-Flex, Tygon, etc.)
- Easily assembled with ordinary skill (no tools required) Stand-alone temperature controller with an alarm circuit to safeguard your cells
- Near laminar flow

Uniform temperature, closed, live-cell environmental chamber.

**FCS3 Closed Chamber for Upright Microscopy**

Closed System Live Cell Environmental Chamber System for Upright Microscopes

The FCS3 provides the user with all of the functionality of the popular FCS2 but redesigned for upright microscopes.

What is it?

The Focht Chamber System 3 (FCS3) is a live-cell micro-observation system specifically for upright microscopes. It has all of the optical, thermal and fluidic capabilities of its predecessor the FCS2. Therefore, it provides compatibility with all modes of microscopy, uniform temperature control throughout the observation aperture, a near laminar flow that is adjustable to provide the user with the ability to modify the separation of optical surfaces, flow path geometry, and fluid volume.



How does it work?

Temperature Control

The FCS3 was designed to maintain accurate thermal control and allow near laminar flow perfusion. Both of these functions are incorporated into our patented Microaqueduct Slide (see drawing below). The surface of the slide, opposite the specimen side, is coated with an electrically conductive transparent thin film of Indium-Tin Oxide (ITO) and two electrical contacts (busbars). When the FCS3 is completely assembled and placed on the stage adapter, two electrical contacts and a thermal sensor, (not shown in drawing), rest on these busbars. A temperature controller is used to pass a regulated current flow through the ITO Coating. This causes the surface of the slide to heat. The heat is transferred through the media to the cell surface on the coverslip thereby providing a conductive heat transfer. The metal base of the chamber is also temperature regulated to provide heat to both the incoming media and peripheral thermal support to the metal housing.

Microaqueduct Slide

Microaqueduct Perfusion: A fluid pathway is formed by separating the Microaqueduct slide from the coverslip containing cells with a single silicone gasket. This gasket can be any thickness from 50 micron to 1mm and any lateral geometry you choose or create. This arrangement allows the user to define the flow characteristics. Therefore, you are not limited by the geometry of the optical cavity instead you select or create it! Fluid access to this flow channel is made through two 14-gauge needle stock tubes protruding from the sides of the chamber top. These tubes provide fluid connection to two perfusion holes in the Microaqueduct slide that interface two "T" shaped grooves cut into the inner surface of the Microaqueduct slide. The "T" groove allows the media to seek the path of least resistance and become nearly laminar before flowing across the cells. This technique eliminates the need for the metal perfusion ring and additional gaskets, which are the limiting factors, required by most conventional chambers.

Microaqueduct design enables proper Koehler illumination with high-numeric aperture optics for both transmitted and reflected modes of microscopy.

The system is comprised of:

- Chamber (environmental optical cavity)
- Electronic Controller
- Stage Adapter

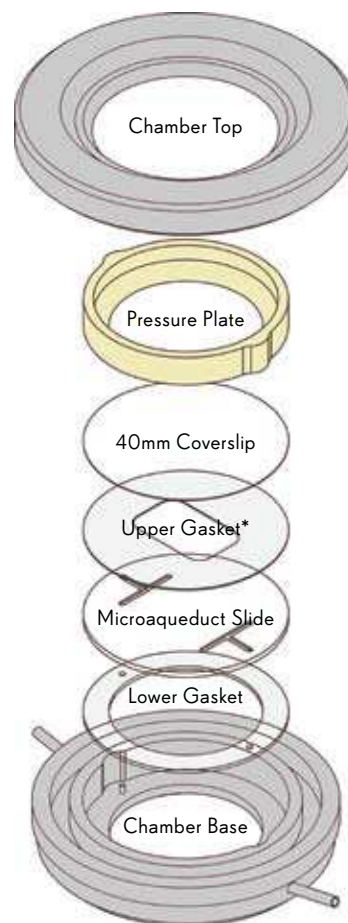

FCS3 Closed Chamber Ordering Information

Part No.	Product Description
Bi-21-060319-3	FCS3 Starter Set: FCS3 Chamber, Chamber Controller, 5 Microaqueduct Slides, 50- #1.5,40mm Coverslips, and Gasket Set (30/set)
Bi-21-060319-3-08	FCS3 Universal Upright Stage Adapter -other sizes avail.
Bi-21-060319-3-03	FCS3 Chamber
Bi-21-060319-3-0303	FCS3 Chamber Controller
Bi-060319-2-0719	FCS3 Gasket Set (30/set)
	Complete Bioptechs product line available.

Email or visit web store for latest prices.



Specifications

The Controller is specifically designed to slowly heat the objective over a fifteen minute warm-up period then hold the objective at the set point value within 0.2 degrees C. The Controller operates from ambient to 50 degrees C and has special safety circuitry which utilizes a 0.9 degrees C error window to shut down the controller and sound an alarm if, for any reason, the temperature of the objective deviates after it has reached set point. A user calibration test is also built in to the controller.

Objective diameters:

17mm to 38mm

Sensor:

Thermistor

Temperature range:

Ambient to 43°C 1.3 Watt

Temperature stability

±0.2°C Typically

A patented solution for immersion objectives.



Objective Heating and Cooling System

The Problem

When high numeric aperture objectives are used to observe temperature sensitive specimens, heat from the specimen is transferred through the optical coupling medium (oil, glycerine, or water) to the colder objective. Therefore, it is necessary to control the temperature of the objective. It is important to understand that when the system is set up properly, the objective heater is only used to prevent heat loss from the specimen. It should not be used to provide heat to the specimen.

The Solution

To eliminate the heat loss from the specimen, Bioptechs developed a patented Objective Heater System[®], which includes a heater/sensor and an electronic controller specifically designed for this purpose. The heater/sensor is comprised of an adjustable thin-film heating band which surrounds 3/4 of the diameter of the upper region of the central retracting tube of the objective. A temperature probe positioned in the gap formed between the ends of the heating band provides accurate feedback to a closed loop controller. A metal cube shaped frame supports a thermal sensor and contains a mechanism to adjust the size of the heater-band.

The Objective Controller[®] is specifically designed to slowly heat the objective over a fifteen minute warm-up period, then hold the objective at the setpoint

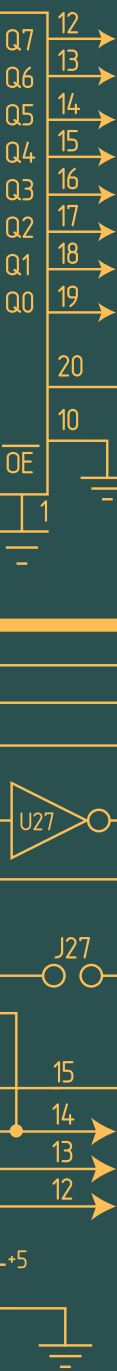

Objective Heating and Cooling System

The Problem

When high numeric aperture objectives are used to observe temperature sensitive specimens, heat from the specimen is transferred through the optical coupling medium (oil, glycerine, or water) to the colder objective. Therefore, it is necessary to control the temperature of the objective. It is important to understand that when the system is set up properly, the objective heater is only used to prevent heat loss from the specimen. It should not be used to provide heat to the specimen.



Special note:

1. When using warmed objectives it is recommended to use Type 37 Immersion Oil, available from Biotech's. This oil is specially formulated to have a refractive index of 1.518 at 37°C.
2. The Biotech's Objective Heater® can be adapted to fit all objectives. Due to the size, geometry and thermal characteristics of some objectives, it may be necessary to use a thermal spacer to eliminate the influence of the nosepiece.

Objective Cooling Collar

The Objective Cooling Collar is an attachment to an objective that provides an isolated pathway through which a refrigerated fluid can flow. This provides an efficient means of cooling the objective. The source of the chilled fluid can be as simple as a dewar of ice water or as sophisticated as an AC powered chiller bath. The removal of heat from the objective is more difficult than heating because you are limited by the thermal transfer efficiency of both the objective and the contact surface of the cooling ring. Therefore, the cooling ring needs to be of sufficient size to work. It is advisable to make sure you have enough room under the stage for the additional diameter required for the cooling collar and tubing. Cooling collars are precision machined to fit specific objectives.

Objective Heating and Cooling Ordering Information

Part No.	Product Description	
Bi-150803	Objective Heater Controller	
Bi-150819	Objective Heater, Standard (16-28mm)	
Bi-150815	Objective Heater, Medium (24-32mm)	
Bi-150812	Objective Heater, Large (26-35mm)	
Bi-150303	Objective Cooling Collar	
	Complete Biotech's product line available.	

Email or visit web store for latest prices.

800.998.MATE | www.autom8.com | 812 Page Street, Berkeley, CA 94710 USA
tel 510.845.6283 | fax 510.280.3795 | e-mail info@autom8.com

AutoMate Scientific®
READY FOR RESEARCH.™



Micro-Perfusion Pump Features:

- Compact
- Usable as either single or dual channel
- Precise speed setting feature
- Flow rates of 0.2 to 180 ml/hr
- Compatible with 1/16" tubing
- External DC power supply with internal 9 volt backup battery
- Can be operated on internal battery if desired
- Computer interface available

Program and record perfusion flow and temperature over USB.



Perfusion Pump and Software

When imaging cells in a rigid structure such as a chamber having a coverslip as an observation surface, one must appreciate the fact that any rapid changes in flow rate will translate to microdynamic changes in pressure within the optical cavity of the chamber. This causes the coverslip to behave like a diaphragm thus flexing out of focus due to the narrow depth of field of the microscope objective. To eliminate this problem at the lower flow rates and significantly reduce it at higher flow rates, Biotech's recommends the Micro-Perfusion pump for use with all its micro-observation systems.

The Micro-Perfusion Pump is a miniature, single or dual, channel, full-featured peristaltic pump designed specifically for low-flow rates. Unlike most peristaltic pumps that are driven by stepper motors, the Micro-Perfusion pump is driven by a tachometer regulated, multi-stage DC gear motor. This assures a smooth analog rotation of the roller spindle, free of instantaneous steps. It is regulated by either the internal control circuitry adjustable from 0.2-180 ml/hr or it can be interfaced with a computer through a DAIO port. Biotech's provides a kit for this purpose that includes all cabling, software, and hardware needed for a dual pump setup. The pump comes with an external 9 volt AC adapter and also contains an internal 9 volt battery which can function as the primary power supply if needed.

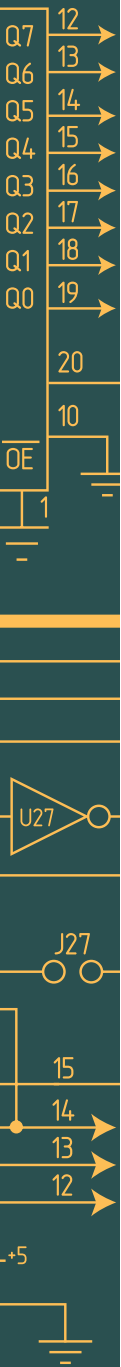

The pump includes a single .062" I.D. tube and a dual tube that has two .062" I.D. tubes for use as a dual channel pump. Although other tubing sizes are available, this size is generally best suited for imaging applications. The pump tubes are available in silicone rubber and C-Flex. They are terminated with a 1/16" tubing barb. The base of the pump is threaded for easy mounting to a stand or fixture near the microscope.

Perfusion / Temperature Control Computer Interface

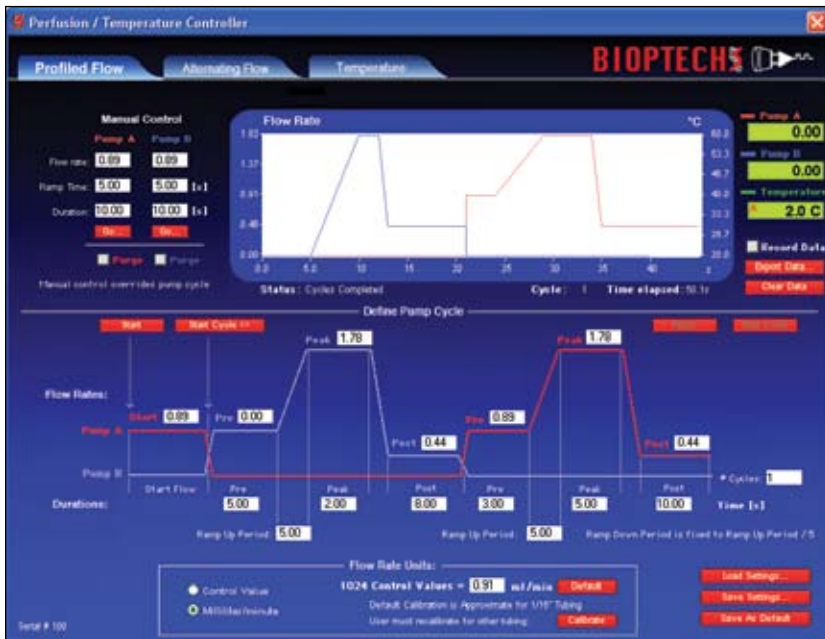

The live-cell microscopy Perfusion and Temperature Control Interface from Biopetechs™ features:

- Extreme ease of use with precise and repeatable control
- Dual or single micro-perfusion pumps
- Flow profile to reduce dead volume delays
- Temperature and perfusion recording
- Data logging of perfusion and temperature
- Multi flow-rate calibration
- Temperature profiling and cycling
- Saving and reloading settings
- Graphic display of events

Perfusion Pump Ordering Information

Part No.	Product Description
Bi-60319131616	Micro-Perfusion Pump -specify desired flow rate(s)
Bi-13161603-13	Perfusion/ Temperature Controller (USB interface)
Bi-60319192016	Single Channel Pump Tubing Assembly (4/pk) C-Flex
Bi-16181303	Perfusion Pump Rod Mounting Clamp
	Complete Biopetechs product line available.

U.S./Canada prices shown. International prices add 15%. Email or visit web store for latest prices.

This intuitive control interface system is optimized for time lapse imaging of live-cell activity. It provides a convenient, accurate, reliable, and repeatable method of controlling fluid and temperature for chemically or thermally induced change experiments in live-cell chambers. It is WYSIWYG on both Mac and Windows platforms!

USB Data Acquisition Function Module

Plugs into the USB port on Windows or Macintosh computers.

Pumps

Plug the pumps into the USB Data Acquisition Function Module and control two separate perfusion sources.

Computer Control

Control and Record Experiments!

Plug the FCS2, Delta T or Objective Heater into the USB Data Acquisition Function Module and have temperature control of your experiment, with the ability to record temperature data.

